



JEEP® GRAND CHEROKEE | 2007





Experience North American freedom of choice. From its auspicious award-winning launch, and on through today's icon of luxurious comfort, Jeep® Grand Cherokee continues to blaze a trail of industry innovations. In 2007, you're invited to exercise the freedom to choose from the largest selection of engines and four-wheel-drive systems available in any SUV in its class.* For example, opt for the staggering 6.1L SRT HEMI® V8 engine in the exclusive SRT8, pick the hearty and efficient 3.0L V6 Turbo Common-Rail Diesel (late availability) or choose from three other highly fit engines. A solid net of standard safety and security systems have helped Grand Cherokee earn the U.S. Government's highest rating – ★★★★★ – five stars for front and side impact crash testing.** Luxury, capability, security, freedom: Jeep Grand Cherokee. Enjoy.

*Based on 2006 *Automotive News* Lower Mid-Range Sport Utility Segment. **Based on U.S. Government's National Highway Transportation Safety Administration (NHTSA) scoring system for 2007 Jeep Grand Cherokee.



1949 Willys Jeep Station Wagon

.....

The 1949 Willys Jeep Station Wagon, in its 4x4 form, made headlines as the industry's first sport utility wagon. One of the most influential vehicles ever built, it effectively heads an unbroken line of history-making Jeep wagons, culminating with today's luxuriously capable Jeep Grand Cherokee.



JEEP® GRAND CHEROKEE OVERLAND SHOWN IN JEEP GREEN METALLIC



NEW 4.7L FFV V8 ENGINE.

Introducing "Flexible Fuel Vehicle" technology that allows you to run on any combination of gas or E85 ethanol



NEW 3.0L V6 TURBO COMMON-RAIL DIESEL ENGINE. Advanced technology generates impressive performance; its diesel particulate filter helps it burn cleaner. Grand Cherokee is the only diesel-powered vehicle in its class.^[1] (Late availability.)

NEW PARKVIEW™ Working in conjunction with the ParkSense™ Rear Park Assist system and the available GPS navigation system, you can be camera-assisted in Reverse.^[2]

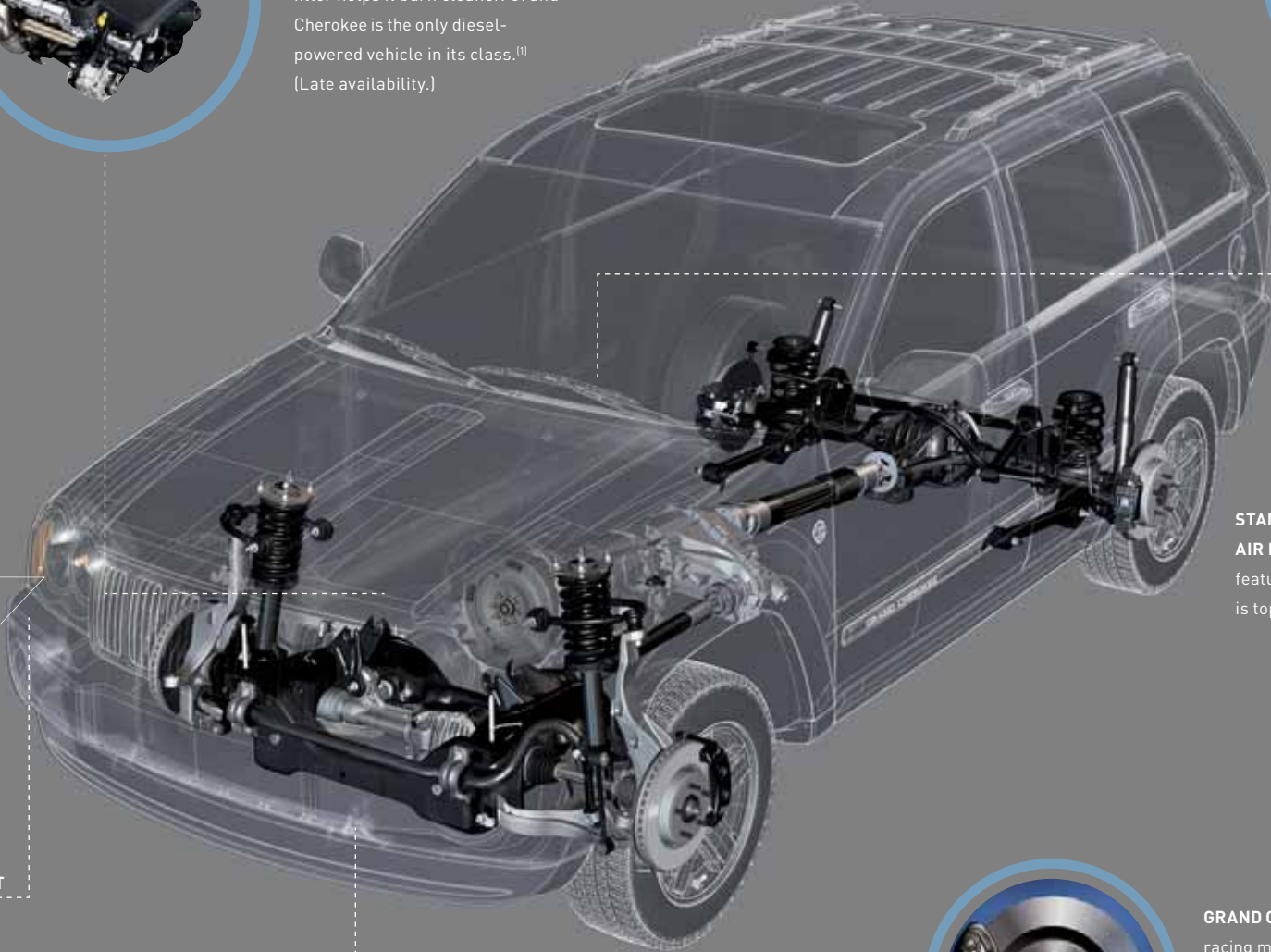

STANDARD SIDE-CURTAIN AIR BAGS^[3]. These standard features prove occupant safety is top-of-mind.



GRAND CHEROKEE SRT8. This racing machine features four-piston Brembo® brake calipers on all four wheels for high-performance braking response.

EXCLUSIVE SMARTBEAM™ INTELLIGENT HEADLAMP SYSTEM. Need high beams in the city? The answer's automatic with this sophisticated aid for night-time driving.

NEW ACTIVE TURN SIGNALS. One gentle touch automatically generates three signal blinks.

QUADRA-DRIVE II™ FOUR-WHEEL-DRIVE SYSTEM. This amazing workhorse raises 4WD capability to a whole new level with revolutionary front and rear Electronic Limited-Slip Differentials and an electronically controlled centre clutch pack. It can transfer up to 100 percent of available torque to any wheel with traction within a fraction of a second.

^[1]Based on 2006 *Automotive News* Lower Mid-Range Sport Utility segment. ^[2]Intended to provide assistance to the driver. Always exercise appropriate care while reversing. ^[3]Always use seat belts. Children 12 and under should always be in a back seat correctly using an infant or child restraint system, or the seat belt properly positioned, dependent on the child's age and weight.



CONFIDENT ON-ROAD CONTROL

Successfully navigate challenging driving conditions, including icy pavement, unexpected potholes and slick, rain-covered asphalt. Grand Cherokee leads the way, due to premium features that help you maintain vehicle control.

[A] The independent front and live-axle rear suspension system on Grand Cherokee works to help keep your ride smooth and consistently under control.

[B] The Electronic Stability Program (ESP)⁽¹⁾ works in tandem with the anti-lock brake system (ABS) and Brake Traction Control System to help you keep your vehicle on course. When ESP is engaged, a special indicator light flashes on the instrument panel.

[C] Four-Wheel Brake Traction Control utilizes ABS to limit wheel slip and improve control during acceleration – during extreme conditions it can apply braking measures on up to three wheels, driving torque to the wheel with traction.

[D] Quadra-Drive II™ lets you engage 4LO when driving at speeds not exceeding 40 km/h (25 mph). 4LO locks the centre differential, multiplying engine torque 2.72 times, for supreme Jeep® 4WD power to conquer the most challenging on- or off-road conditions.

⁽¹⁾No system, no matter how sophisticated, can repeal the laws of physics or overcome careless driving actions. Performance is limited by available traction, which snow, ice and other conditions can affect. When the ESP warning lamp in the speedometer flashes, the driver needs to use less throttle and adapt speed and driving behavior to prevailing road conditions. Always drive carefully, consistent with conditions. Please always wear your seat belt.



Systematic choices for ultimate capability. Having your choice between some of the most advanced 4WD systems on the planet is a good thing. Even better, with four available 4WD systems, Grand Cherokee leads the pack. When you're equipped with any one of these advanced 4WD systems, greater confidence, wherever you choose to drive, is simply part of the plan.

Quadra-Drive II™: With front and rear Electronic Limited-Slip Differentials (ELSD) that can help transfer 100 percent torque to any one wheel with traction. Trail Rated™ Quadra-Drive II enables Grand Cherokee to climb up the rockiest hills and through the deepest snowdrifts for ultimate traction control during severe road conditions.

Quadra-Trac II™: The innovative all speed traction control built into this Trail Rated system helps keep you safely on course. If wheel slippage is detected, up to 100 percent of the available torque is routed to the axle with the most traction. Shift into low gear for even greater performance to conquer challenging conditions, on- and off-road.

Quadra-Trac I®: Standard on Laredo, this full-time system operates smoothly, with no driver interaction required. Under normal driving conditions, torque is distributed 48 percent to the front wheels and 52 percent to the rear wheels. If wheel slippage occurs, the integrated traction control system helps transfer torque to those wheels with traction for secure 4WD capability when driving on-road during hazardous weather conditions.⁽¹⁾

SRT 4WD: It can harness 420 hp and 420 lb-ft of torque to launch Grand Cherokee SRT8 from 0–60 mph (0–96 km/h) in under five seconds, on wet or dry pavement. That's the power behind the SRT 4WD system. It's built to handle the burly 6.1L SRT HEMI® V8 engine – and that it does for powerful on-road traction; not intended for off-road use.

⁽¹⁾Quadra-Trac I is not appropriate for conditions or situations where low range is required, such as severe off-road driving conditions.



Grand Cherokee is designed to make your life on the road an easy ride, no matter where you choose to travel. Its sophisticated front and rear suspension designs work together to help keep all four tires in contact with the ground below for greater off-road articulation and on-road security.

GRAND CHEROKEE 4x4 POWERTRAINS | Overland – Quadra-Drive II + 5.7L HEMI V8 Engine (3.0L V6 Turbo CRD Engine Optional) | Limited – Quadra-Trac II (Quadra-Drive II Optional) + 4.7L FFV V8 Engine (5.7L HEMI V8 Engine/3.0L V6 Turbo CRD Engine Optional) | Laredo – Quadra-Trac I (Quadra-Trac II/Quadra-Drive II Optional) + 3.7L V6 Engine (4.7L FFV V8 Engine/3.0L V6 Turbo CRD Engine Optional) | SRT8 – 6.1L SRT HEMI V8 Engine + SRT 4WD

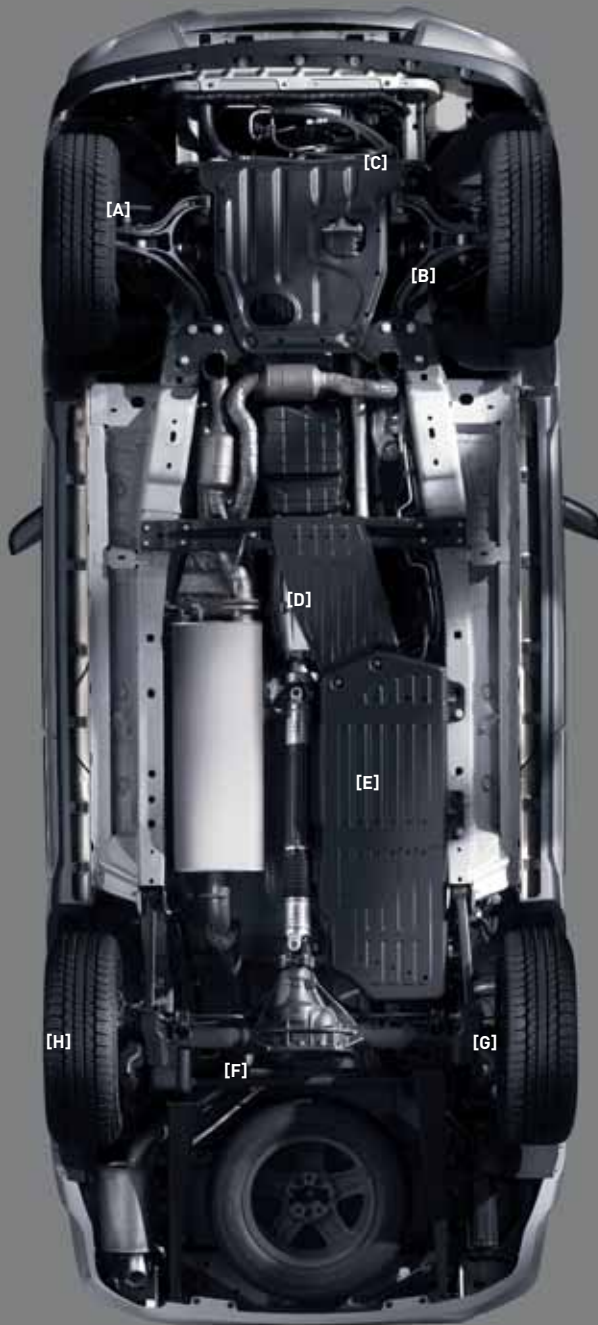

[A] ELECTRONIC STABILITY PROGRAM (ESP™)⁽¹⁾ Assists driver in maintaining control of the vehicle during extreme steering manoeuvres by automatically controlling the throttle and applying the brakes on individual wheels. Electronic Roll Mitigation is a complementary ESP feature that lessens the chance of wheel lift occurring during severe or excessive driving manoeuvres. Standard.

[B] INDEPENDENT SHORT/LONG ARM FRONT SUSPENSION SYSTEM Allows front wheels to act and react independently for improved wheel articulation. You will enjoy a smooth, stable ride. Standard.

[C] VARIABLE-RATIO RACK AND PINION STEERING A nimble, power-assisted steering system that provides a quick response during tricky parking lot manoeuvres and precise navigation on the highway. Standard.



[D] QUADRA-DRIVE II™ Front and rear ELSD in Quadra-Drive II team up with the NV245 active transfer case and its electronically controlled centre clutch pack to deliver rock-solid traction management. Switch into 4WD Low to lock the Quadra-Drive II transfer case clutch pack. Engine torque is multiplied 2.72 times. Available.

[E] SKID PLATES Help protect your investment from off-road rocks and on-road debris. Front suspension and drivetrain plates are constructed of 3 mm thick stamped steel. Available.

[F] STABILIZER BAR Helps keep the vehicle body flat through turns. Premium Teflon® lined bar bushings help reduce friction and noise. Standard.

[G] MULTILINK REAR SUSPENSION SYSTEM Lateral stiffness is improved, reducing side-to-side body roll that causes the undesired “head toss” motion felt in less capable systems. Standard.

[H] FOUR-WHEEL ANTI-LOCK BRAKE SYSTEM (ABS) Equipped with electronic sensors that prevent wheel lockup, ABS offers improved steering control under extreme braking and/or slippery conditions. Standard.

⁽¹⁾No system, no matter how sophisticated, can repeal the laws of physics or overcome careless driving actions. Performance is limited by available traction, which snow, ice and other conditions can affect. When the ESP warning lamp in the instrument cluster flashes, the driver needs to use less throttle and adapt speed and driving behaviour to prevailing road conditions. Always drive carefully, consistent with conditions. Please always wear your seat belt



Jeep Trail Rated™ vehicles are designed to perform in a variety of off-road conditions identified by five performance categories:



ARTICULATION: The ability to keep tires in contact with the road, providing traction to climb over large obstacles.

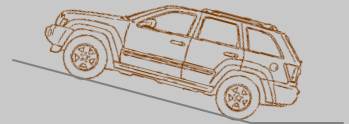

TRACTION: The ability to transfer power down to the road or trail along with the ability of the suspension to keep the wheels in contact with the terrain.



MANOEUVRABILITY: The ability to navigate around obstacles that are tightly situated.



GROUND CLEARANCE: The ability to drive over obstacles or logs in combination with approach/departure/breakover angles.



WATER FORDING: The ability to cross a specific depth of water at a specific speed.

Do not attempt water fording unless depth is known to be less than 508 mm (20 inches). Traversing water can cause damage that may not be covered by the new vehicle warranty. Always off-road responsibly in approved areas.



POWER

JEEP® GRAND CHEROKEE → PAGE 8 | JEEP.CA



3.0L V6 Turbo CRD



5.7L HEMI® V8



4.7L FFV V8



3.7L V6



6.1L SRT HEMI V8



Empowering choices. Grand Cherokee gives you more engine choices than any other vehicle in its class.⁽¹⁾

All New 3.0L V6 Turbo Common-Rail Diesel (CRD) Engine (late availability): The new 3.0L V6 Turbo CRD engine incorporates advanced technology that's shared with Mercedes-Benz, resulting in excellent fuel economy and driving range. You'll harness 215 hp and 376 lb-ft of torque that can accelerate Grand Cherokee from 0-60 mph (0-96 km/h) in nine seconds – stats like these rival or trump many V8 engines. Yet with its single, highly pressurized fuel rail connected to piezo injectors, fuel is burned more completely, creating the optimum blend of power and efficiency. A Variable Geometry Turbocharger and an integrated diesel particulate filter help reduce fuel consumption, exhaust emissions and engine noise. **5.7L HEMI® V8 Engine:** For jaw-dropping power, choose Grand Cherokee's available 5.7L HEMI V8 with its fuel-saving Multi-Displacement System (MDS).⁽²⁾ Maintain your cruising speed between 64 and 96 km/h (40 and 60 mph) and four of the engine's eight cylinders seamlessly deactivate, adding gas-saving economy.⁽²⁾ Put your foot down and the HEMI engine's 330 hp help you rule the road. Its incredible 375 lb-ft of torque jets you into passing or merging mode with ease. Its lightweight, heavy-duty pistons incorporate race-proven design elements that are amazingly quiet during operation. **4.7L Flexible Fuel Vehicle (FFV) V8 Engine:** This versatile workhorse can run on regular gas or ecologically friendly E85 – without compromising power or performance. Fill your tank with either fuel and you'll still command 235 hp and 305 lb-ft of torque. **3.7L V6 Engine:** This efficient, durable performer features a sophisticated electronic throttle control system for exceptional smoothness. **6.1L SRT HEMI V8 Engine:** Available exclusively on Grand Cherokee SRT8, this specially engineered power plant delivers a whopping 420 hp that can shoot the strong-hearted from 0-60 mph (0-96 km/h) in less than five seconds.

⁽¹⁾Based on 2006 *Automotive News* Lower Mid-Range Sport Utility segment ⁽²⁾2007 EnerGuide fuel consumption estimates of 16.5L/100 km city/11.2L/100 km highway (17 mpg city/25 mpg highway)



A network of standard safety and security systems. Grand Cherokee's **Electronic Stability Program (ESP™)**⁽¹⁾ is ingeniously integrated with an **Electronic Roll Mitigation (ERM)** program. Their computerized sensors constantly compare whether the vehicle's course of travel matches the driver's intention. Should an inconsistency be detected, ESP initiates to instantly help stabilize the vehicle, employing ERM if necessary. ESP may also activate **Brake Assist**, integrated into the advanced four-wheel **anti-lock brake system (ABS)**, to automatically activate selected braking patterns to aid stabilization. **Standard side-curtain** and **advanced multistage front air bags**⁽²⁾ work in tandem to provide protection as well.

Choose the available ultrasonic **ParkSense™ Rear Park Assist System**⁽³⁾ to help you clear tight spots. Vehicles equipped with the available **GPS Navigation System** can also choose **ParkView™**⁽³⁾ a new optional rear back-up camera that assists in the detection of hidden obstacles during reverse manoeuvres. For night-time driving security, the **SmartBeam™ intelligent headlamp system** automatically and quickly adjusts high-beam brightness and intensity, a standard feature on Overland and Limited.



The Tire Pressure Monitoring System notifies you if any tire loses air pressure. The available display system (shown) transmits individual tire pressure.



Based on 2007 model year ratings, Grand Cherokee has earned the U.S. Government's highest rating – ★★★★★ – five stars for front and side impact crash testing.*

*Based on U.S. Government's National Highway Transportation Safety Administration (NHTSA) scoring system for 2007 Jeep Grand Cherokee. ⁽¹⁾No system, no matter how sophisticated, can repeal the laws of physics or overcome careless driving actions. Performance is limited by available traction, which snow, ice and other conditions can affect. When the ESP warning lamp in the instrument cluster flashes, the driver needs to use less throttle and adapt speed and driving behaviour to prevailing road conditions. Always drive carefully, consistent with conditions. Please always wear your seat belt. ⁽²⁾Always use seat belts. Children 12 and under should always be in a back seat correctly using an infant or child restraint system, or the seat belt properly positioned, dependent on the child's age and weight. ⁽³⁾Intended to provide assistance to the driver. Always exercise appropriate care while reversing.





Overland. The ultimate Grand Cherokee experience. A wish list of premium capability, comfort and entertainment features are all standard, making Jeep® Grand Cherokee Overland one of the most physically fit 4x4 SUVs on the road today. Gorgeous platinum exterior accents garner a great deal of attention, but take a look under the hood for more of the Overland story. Its enviable powertrain begins with the brawny 5.7L HEMI® V8 engine with its fuel-saving Multi-Displacement System (MDS)⁽¹⁾ paired with the class-leading king of 4WD, Quadra-Drive II™. Yet with all of this infusion of power, you still experience a gloriously quiet ride. Hundreds of sound-dampening elements are fully integrated into Grand Cherokee Overland's design. Even its UniFrame body and safety cage includes Quiet Steel® technology that reduces noise, vibration and ride harshness. Combine all these standard premium features with its legendary Jeep Brand "go anywhere, do anything" character, and you'll know that saying one word can put you on the trail of the ultimate Grand Cherokee: Overland.

Welcome to ingenious sophistication. With distinctive attention to detail, Jeep® Grand Cherokee Overland's exquisite interior boasts an unparalleled number of premium features. This is in addition to the standard heated, Preferred Suede™ Microfibre and leather-faced front seats. New active turn signals only require one gentle touch on the turn stalk to indicate your intention to change lanes. The standard six-speaker Boston Acoustics® Premium Sound System with an impressive 276-watt digital amplifier surrounds you with sounds emanating from the speakers of the standard AM/FM stereo with six-disc CD/MP3 player.

⁽¹⁾2007 EnerGuide fuel consumption estimates of 16.5L/100 km city/11.2L/100 km highway (17 mpg city/25 mpg highway).

The available Rear Seat DVD Video Entertainment System™ provides fun for back seat passengers. The screen conveniently folds down from the headliner and the player stores nicely in the centre console.

GRAND CHEROKEE OVERLAND | STANDARD | 5.7L HEMI V8 Engine with MDS and Multispeed Automatic Transmission | Quadra-Drive II 4WD with Front and Rear ELSD | Electronic Stability Program with Electronic Roll Mitigation | AVAILABLE | 3.0L V6 Turbo CRD Engine



JEEP® GRAND CHEROKEE OVERLAND SHOWN IN BLACK



LIMITED

JEEP® GRAND CHEROKEE → PAGE 12-13 | JEEP.CA



Limited displays unlimited elegance all its own. Jeep® Grand Cherokee Limited shines with spectacular exterior chrome details on the traditional Jeep Brand seven-slot grille and body trim. Limited also delivers a healthy dose of punched-up premium on-road power, thanks to a standard 4.7L FFV V8 engine that's paired with the Quadra-Trac II™ 4WD system. Those craving more can move up to the available 5.7L HEMI® V8 and Quadra-Drive II™ 4WD system. An increased fuel capacity puts more room in your tank and more miles between fill-ups. Standard safety and security features include anti-lock brake system, Electronic Stability Program with Electronic Roll Mitigation, Tire Pressure Monitoring Display System and SmartBeam™ intelligent headlamp system.

The inside story is very distinguished. Jeep® Grand Cherokee Limited's spacious and well-crafted interior welcomes you and your guests; its well-appointed cabin makes every ride a pleasurable adventure. Leather-faced two-tone heated front seats are supportive and ultra-cushioned. The standard infrared dual zone climate control with sun sensors and rear seat heat and air conditioning outlets create a customized interior environment. The standard sunroof with its convenient one-touch express operation offers an instant breath of fresh air.

The new 4.7L Flexible Fuel Vehicle (FFV) V8 engine runs on any combination of gasoline or E85 ethanol, an environmentally friendly alternative energy source.

Let the available GPS navigation system be your automatic co-pilot with full colour maps and detailed, turn-by-turn directions. Its 5.8-inch display screen and six-disc CD/MP3 player help keep you on track geographically and musically.

GRAND CHEROKEE LIMITED | STANDARD | 4.7L FFV V8 Engine with Multispeed Automatic Transmission | Quadra-Trac II 4WD | AVAILABLE | 5.7L HEMI V8 Engine | 3.0L V6 Turbo CRD Engine | Quadra-Drive II 4WD with Front and Rear ELSD | Trailer Tow Group



JEEP® GRAND CHEROKEE LIMITED SHOWN IN MINERAL GREY METALLIC



Laredo is loaded with standard capability and style. For refined value infused with authentic Jeep® Brand DNA, choose Jeep Grand Cherokee Laredo. Its variable-ratio rack and pinion steering, independent front/multilink rear suspension system, ESP with Electronic Roll Mitigation and Tire Pressure Monitoring Warning System are all standard. Laredo offers plenty of capability too, with the Quadra-Trac I® full-time 4WD system paired with the economical 3.7L V6 engine or the optional Quadra-Drive II™ matched to the 3.0L Turbo CRD engine†. A generous cargo capacity of 1909L (67.4 cu. ft) holds plenty of gear.* Start your Laredo from 70 m (230 ft) away with the available Remote Start System.

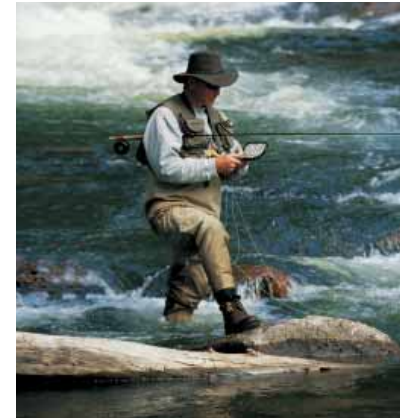

Your Grand Cherokee Laredo is engineered to augment an active lifestyle. You can fold down the rear 60/40-split folding seats to reveal a generous cargo capacity of 1909L (67.4 cu. ft). It has room enough to hold plenty of gear or transport supplies for weekend home improvement projects*.

Standard interior features that include many storage bins and pockets, manual climate control with rear seat outlets, and a waterproof cargo insert contribute to Laredo's great package appeal.

†Late availability.
*Properly secure all cargo.

GRAND CHEROKEE LAREDO | STANDARD | 3.7L V6 Engine with 5-Speed Automatic Transmission | Quadra-Trac I 4WD | All Speed Traction Control | AM/FM Stereo Radio and CD Player | AVAILABLE | 4.7L FFV V8 Engine with Multispeed Automatic Transmission | 3.0L V6 Turbo CRD Engine† | Quadra-Trac II™ 4WD | Quadra-Drive II 4WD | SIRIUS™ Satellite Radio† | UConnect™ Hands-Free Communication System



JEEP® GRAND CHEROKEE LAREDO SHOWN IN STEEL BLUE METALLIC



Even the cabin is built for speed and style. Race-inspired front seating and a refined aluminum finish on the instrument panel, shifter bezel, steering wheel and floor console help give SRT8 a sporty look.

Twin chrome 4-inch exhaust tips over a genuine dual exhaust system with 2¾-inch-diameter pipes speak volumes about SRT8's power.



The ultimate performance-based 4WD racing machine. When *Car and Driver* (March 2006)

magazine states, "This thing explodes when you jump on the gas," you know they're not talking about a run-of-the-mill 4x4 SUV. Jeep® Grand Cherokee SRT8 claims the auspicious title of "Fastest Vehicle in Its Class"⁽¹⁾ by taking the ultimate in street performance technology and infusing it with authentic Jeep Brand DNA. Settle into SRT8's race-inspired seating to command a 420-hp 6.1L SRT HEMI® V8 engine with 420 lb-ft of torque and an estimated top speed of over 240 km/h (150 mph). This beast can launch you from 0-60 mph (0-96 km/h) in under five seconds, on either wet or dry pavement. Only the beefed-up SRT 4WD system with its active full-time transfer case and all speed traction control has the guts to handle this kind of action. SRT8's incredible velocity is only countered by its four-piston Brembo® Performance brake calipers and massive 14.2-in. front and 13.8-in. rear rotors, cooled by integrated, fully functional brake ventilation ducts. These components all work together to give you optimal stopping power on or off the track.

⁽¹⁾Based on 2006 *Automotive News* Lower Mid-Range Sport Utility segment 0-60 performance.

GRAND CHEROKEE SRT8 | STANDARD | 5-Speed Automatic Transmission with Electronic Range Select | SRT 4WD Active Full-Time Transfer Case | Electronic Stability Program with Electronic Roll Mitigation | Performance-Tuned Suspension and Steering | 20-Inch Goodyear Run-Flat Tires with Polished Forged Aluminum Wheels | Boston Acoustics® Premium Sound System | AVAILABLE | Full Screen GPS Navigation System | Rear Seat DVD Video Entertainment System™



JEEP® GRAND CHEROKEE SRT8 SHOWN IN RED ROCK CRYSTAL PEARL



COLOUR & TRIM

JEEP® GRAND CHEROKEE → PAGE 18-19 | JEEP.CA



Black 1, 2, 3, 4

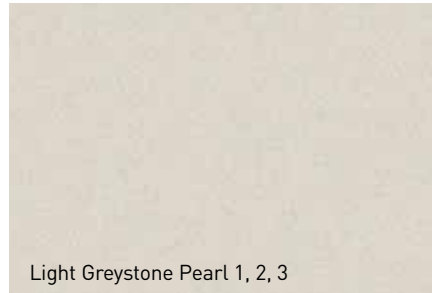

Light Greystone Pearl 1, 2, 3



Mineral Grey Metallic 1, 2



Bright Silver Metallic 1, 2, 3, 4

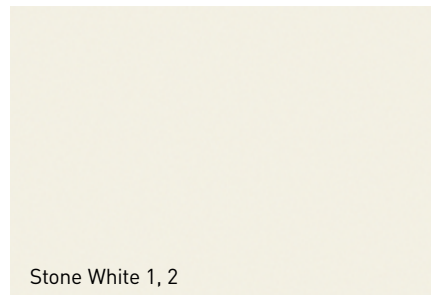

Stone White 1, 2



Jeep® Green Metallic 1, 2, 3



Steel Blue Metallic 1, 2, 3, 4



Red Rock Crystal Pearl 1, 2, 3, 4

LEGEND: 1 Laredo; 2 Limited; 3 Overland; 4 SRT8

NOTE: Due to occasional printing irregularities, the colours shown may vary slightly from actual hues.

LAREDO

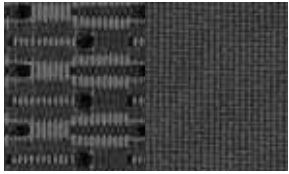

Cloth
Medium Slate Grey
Standard



Leather
Medium Slate Grey
Available

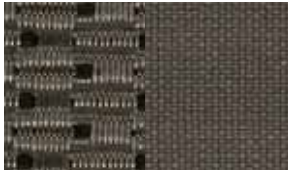

Cloth
Medium Khaki | Standard



Leather
Medium Khaki | Available

LIMITED



Leather
w/Perforated Inserts
Two-Tone Slate Grey
Standard

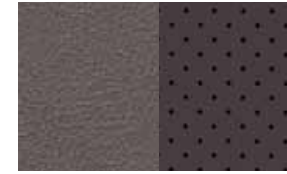

Leather
w/Perforated Inserts
Two-Tone Khaki | Standard

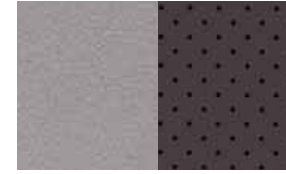

Leather w/Perforated Inserts
Two-Tone Light Greystone/Dark Khaki | Standard

OVERLAND

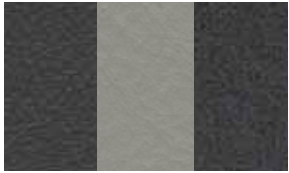

Leather
w/Preferred Suede™
Microfibre Inserts
Two-Tone Slate Grey
Standard

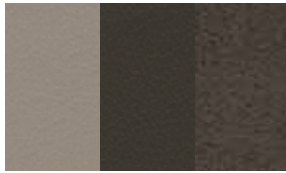

Leather
w/Preferred Suede
Microfibre Inserts
Two-Tone Light Greystone/
Dark Khaki | Standard



SRT8



Leather w/Diamond Embossed
Preferred Suede Microfibre Inserts
Medium Slate Grey/Dark Slate Grey | Standard



LAREDO



17-inch Cast Aluminum
with Satin Silver Finish | Standard

LIMITED



17-inch Cast Aluminum
with Machined Face | Standard



17-inch Chrome-Clad
Cast Aluminum | Available
(also available on Laredo)

OVERLAND



17-inch Chrome-Clad
Cast Aluminum | Standard

SRT8



20-inch Polished
Forged Aluminum | Standard

**POWERTRAIN**

Engine Displacement (cu. in.)	3.0L V6 CRD	3.7L V6	4.7L V8	5.7L HEMI® V8	6.1L SRT HEMI V8
	183	226	287	345	370
Net Power					
kW (hp) @ rpm	160 (215) @ 3800	157 (210) @ 5200	175 (235) @ 4500	246 (330) @ 5000	313 (420) @ 6200
Net Torque					
N-m (lb ft) @ rpm	510 (376) @ 1600-2800	318 (235) @ 4000	414 (305) @ 3600	508 (375) @ 4000	569 (420) @ 4800
Axle Ratio	3.73:1	3.07:1	3.73:1	3.73:1	3.73:1
Fuel System	Common-Rail Direct Injection	Sequential multipoint electronic fuel injection			

Multi-Displacement System (MDS) Deactivates 4 cylinders (1, 4, 6, and 7) during steady speed between 64-97 km/h (40-60 mph), low-acceleration and shallow-grade climbing conditions to improve fuel economy (depending on driving habits)⁽¹⁾ (5.7L HEMI V8)

Transmission 5-speed automatic with Electronic Range Select, Tow/Haul feature, adaptive electronic control, Brake/Park Interlock and electronically modulated converter clutch (3.7L, 6.1L)

Multispeed automatic with 5 forward speeds, alternate 2nd gear, Electronic Range Select, Tow/Haul feature, Brake/Park Interlock and electronically modulated converter clutch (4.7L, 5.7L)

FOUR-WHEEL-DRIVE SYSTEM (transfer case)

Quadra-Trac I® NV140⁽²⁾ Full-time; single-speed with 48/52 front/rear torque split and open front, centre, and rear differentials (3.7L) Std.

Quadra-Trac II™ NV245 Active full-time; 2-speed with low range [2.72:1] and Neutral, variable with 48/52 front/rear default torque split, electronically controlled clutch pack coupling in centre differential and open front/rear differentials (3.0L, 3.7L, 4.7L) Opt.

Quadra-Drive II™ NV245 Active full-time; 2-speed with low range [2.72:1] and Neutral, variable with 48/52 front/rear default torque split, electronically controlled clutch pack coupling in centre differential and front and rear Electronic Limited-Slip Differentials (3.0L, 4.7L, 5.7L) Opt.

SRT NV146 Active full-time; single-speed with variable torque split, electronically controlled clutch pack in centre differential and open front and rear differentials (6.1L) Opt.

CAPACITIES/WEIGHTS kg (pounds) unless otherwise specified

Fuel Tank - L (imp. gal.) (gasoline)	80 (17.5)
(diesel)	83 (18.3)
Base Curb Weight	2036 (4488)
Payload Capacity (with all occupants and cargo)	476 (1050)
Gross Vehicle Weight Rating	
3.0L V6 CRD	2790 (6150)
3.7L V6	2676 (5900)
4.7L FFV V8	2767 (6100)
5.7L HEMI V8	2790 (6150)
6.1L SRT HEMI V8	2790 (6150)

TOWING DATA kg (pounds)

Gross Trailer Weight Rating	
3.0L V6 CRD	3266 (7200)
3.7L V6	1588 (3500)
4.7L V8	2948 (6500) ⁽³⁾
5.7L HEMI V8	3266 (7200)
6.1L SRT HEMI V8	1588 (3500)
Tongue Load Limit (3.7L, 6.1L/3.0L, 4.7L, 5.7L)	238 (525)/342 (750)

Trailer Tow Group Includes frame mounted hitch receiver and 4-pin adapter (3.7L); includes frame mounted receiver hitch and wiring harness with 7- to 4-pin adapter (4.7L, 5.7L) Opt.

RESTRICTION: Trailer frontal area limitation of 5.9 m² (64 sq. ft.); maximum trailer length of 7.6 m (25 ft) [Class II] or 9.1 m (30 ft) [Class IV]; trailer sway control and low-profile mirrors are recommended. This chart is meant to serve as a quick and easy reference guide on how to properly equip your Jeep® Grand Cherokee for towing. For specific details, discuss your plans with your Jeep retailer, who will help you select the right equipment to meet your specifications.

ABOUT THIS CATALOGUE: Since the time of printing, some of this information may have been updated. Ask your retailer for details before ordering. Specifications, descriptions and illustrations contained in this catalogue are based on information believed to be correct at the time this publication was approved for printing. However, accuracy cannot be guaranteed. DaimlerChrysler reserves the right to discontinue models or options at any time or change specifications and materials, equipment or design without notice and without incurring obligation. Some of the equipment may not be exactly as shown in this catalogue.

Some of the equipment, described or illustrated in this catalogue may not be standard, and may be available only at extra cost, as factory installed or retailer installed; items described as "available" may be standard on some models and optional, or not available, on others. Equipment referred to as "available" or "optional" may be at extra cost. Some options are required in combination with other options. For the price of the model with the equipment you desire or verification of specifications and equipment availability described herein, see your Chrysler, Jeep®, Dodge retailer.

Colour availability may vary by model. Due to printing limitations, the colours shown here and throughout the catalogue may vary slightly from the actual hue. See your retailer to view accurate colour chips. Jeep is a registered trademark of DaimlerChrysler Corporation, used under licence by DaimlerChrysler Canada Inc.

©2006 DaimlerChrysler Canada Inc. All rights reserved.

2007 Chrysler, Jeep®, and Dodge vehicles are backed by a 5-year or 100,000-kilometre* fully transferable Powertrain Warranty with \$0 deductible, plus 24-hour roadside assistance.* Basic Warranty coverage is for 3 years or 60,000 kilometres.* Rust-through coverage on all body sheet metal is for 3 years. The Cummins® Turbo Diesel engine is protected by a separate Limited Warranty, covering the engine for 5 years or 160,000 kilometres*.

*Whichever comes first. *Some conditions may apply. The 5/100 Warranty does not apply to vehicles sold for certain commercial uses or to SRT including Viper models. See your retailer for details.

BODY/SUSPENSION/CHASSIS

Body Design UniFrame construction: All steel body sheet metal and frame structural members welded and bonded into a single unit Std.

Suspension

Front: Short/Long Arm (SLA) independent design with coil springs, gas-charged, twin-tube coil-over shock absorbers, upper and lower control arms ("A" arms) and stabilizer bar
Rear: Solid (live) axle, 5-link with tubular track bar, twin-tube coil-over shock absorbers and stabilizer bar

Steering	Rack and pinion, power assisted
Variable Ratio	15.8:1, 13.9:1
SRT8	16.5:1, 14.6:1
Turns (lock-to-lock)	2.85
Turning Diameter - m (ft), curb-to-curb	11.2 (36.7)
SRT8	11.3 (37.1)

BRAKE SYSTEM

Front: Power assisted disc brakes; 12.9" rotor diameter (SRT8 14.2)

Rear: Power assisted disc brakes; 12.6" rotor diameter (SRT8 13.8)

Electronic Stability Program 4-channel, 4-wheel anti-lock with active wheel speed, vehicle speed, steering wheel angle, yaw rate and lateral acceleration sensors, vehicle stability management with 3-stage activation switch, all speed traction control, Brake Assist, Electronic Roll Mitigation and Electronic Brake Distribution Std.

INTERIOR DIMENSIONS mm (inches) unless otherwise specified

Seating Capacity	5 adults
Headroom , front/rear	998 (39.3)/996 (39.2)
Legroom , front/rear	1059 (41.7)/902 (35.5)
Shoulder Room , front/rear	1501 (59.1)/1483 (58.4)
Hip Room , front/rear	1450 (57.1)/1415 (55.7)
Cargo Volume (cu. ft), rear seat up/folded	997 (34.5)/1909 (67.4)

EXTERIOR DIMENSIONS⁽⁴⁾ mm (inches) unless otherwise specified

Length	
Wheelbase	2781 (109.5)
Overall Length	4742 (186.7)
Width	
Overall Width/Body Width	2139 (84.2)/1844 (72.6)
Track, front/rear	1575 (62.0)/1575 (62.0)
Height (overall with roof rails)	1745 (68.7)
Ground Clearance (at base curb weight)	211 (8.3)
Approach Angle/Departure Angle	34.1°/27.0°
Breakover Angle	20.0°

⁽¹⁾2007 EnerGuide Fuel Consumption Estimates: 16.5L/100 km city, 11.2L/100 km highway (17 mpg city, 25 mpg highway)

⁽²⁾Quadra-Trac I is not appropriate for conditions or situations where low range is required - such as severe off-road driving conditions. ⁽³⁾When equipped with Trailer Tow Group. ⁽⁴⁾Dimensions of SRT8: overall length 5525 mm (195.1 in.); track, front/rear 1789/1758 mm (63.3/62.1 in.); height 1909 mm (67.4 in.).

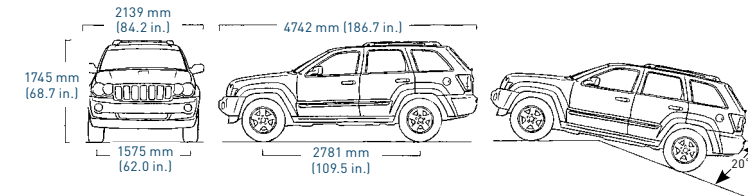

ESP is a trademark of DaimlerChrysler AG. HEMI, Mopar and Quadra-Trac I are registered trademarks of DaimlerChrysler Corporation. ParkSense, Quadra-Drive II, Quadra-Trac II, Rear Seat Video, UConnect, Video Entertainment System, Navus, EVS and ParkView are trademarks of DaimlerChrysler Corporation. Trail Rated and the Trail Rated logo are trademarks of DaimlerChrysler Corporation. Bilstein is a registered trademark of ThyssenKrupp Bilstein GmbH. Boston Acoustics is a registered trademark of Boston Acoustics, Inc. Brembo is a registered trademark of Freni Brembo S.P.A. Preferred Suede is a trademark of Milliken & Company. Quiet Steel is a trademark of Material Sciences Corporation. SmartBeam is a trademark of Gentex Corporation. SIRIUS is a trademark of SIRIUS Satellite Radio Inc. HomeLink is a registered trademark of Johnson Controls Technology Company. Teflon is a registered trademark of E.I. DuPont de Nemours and Company. Cummins is a registered trademark of Cummins Engine Company, Inc. Bluetooth and the Bluetooth logos are trademarks owned by Bluetooth SIG, Inc., U.S.A., and are used by DaimlerChrysler under licence. iPod is a registered trademark and the iPod design is a trademark of Apple Computer, Inc.

In Gear

For those who choose to navigate the city streets or the less travelled paths of the backwoods. Jeep Goods will provide you with rugged high-quality merchandise fit for the Jeep way of life! Jeepgoods.ca



Enhance your Jeep Grand Cherokee with Authentic Jeep Accessories by Mopar. They're designed specifically for your vehicle, for exceptional fit, finish and performance. Visit your retailer or mopar.ca.

	LAREDO		LIMITED	OVERLAND	SRT8
	E	X	H	P	L
CAPABILITY					
Axle Ratio – 3.07:1 (included with V6 engine and Quadra-Trac I ⁽⁹⁾)	•	•			
– 3.55:1 (included with V6 engine and Quadra-Trac II ^(TM))	P	P			
– 3.73:1 (included with V8 engines and CRD)	P	P	•	•	•
Engines – 3.0L V6 CRD Turbo Diesel		0	0	0	
– 3.7L V6	•	•			
– 4.7L FFV V8	0	0	•		
– 5.7L HEMI [®] V8 with MDS			0	•	
– 6.1L SRT HEMI V8					•
Four-Wheel-Drive Systems – Quadra-Trac I ⁽¹⁾ full-time single-speed 4WD includes NV140 transfer case	•	•			
– Quadra-Trac II active 4WD includes NV245 transfer case	0/P	0/P	•		
– Quadra-Drive II ^(TM) active 4WD includes NV245 transfer case and ELSD		P	0/P	•	
– SRT 4WD – Electronic on-demand					•
Skid Plate Group – Includes fuel tank, transfer case, and front suspension skid plates and tow hooks (2 front/1 rear)	0/P	0/P	0/P	•	
Suspension – High-performance suspension tuning with Bilstein [®] monotube shock absorbers and front and rear stabilizer bars					•
Trailer Tow Group – Class II (requires V6), Class IV (requires V8 or CRD)	0	0	0	•	
EXTERIOR					
Cargo Convenience Group – Includes roof rack crossbars and cargo area compartment cover	•	•	•	•	
Lighting – Automatic headlamps (ON/OFF) includes headlamps on with wipers and parade mode features			•	•	•
– Round fog lamps integral with front fascia, water-resistant	0	•	•	•	•
– SmartBeam [™] intelligent high beam headlamp control system (included in SRT Group I)			•	•	P
Wiper System – Rain-sensitive automatic wiper system with rain-sensitive and speed-sensitive intermittent front (included in SRT Group I)			•	•	P
INTERIOR					
Air Conditioning/Heat – Manual temperature control with rear seat outlets	•	•			•
– Infrared dual zone climate control with solar sensors and rear seat outlets (included in SRT Group I)			•	•	P
HomeLink[®] Universal Transceiver⁽²⁾ – Programmable radio frequency codes for garage door, security gate and security lighting			•	•	•
Jeep[®] Memory System – Radio station presets, last station settings, driver's seat position, exterior mirrors and accelerator and brake pedal settings for two drivers (included in SRT Group I)			•	•	P
Pedals – Power adjustable	P	•			
– Power adjustable with memory (included in SRT Group I)			•	•	P
Remote Start – (included in SRT Group I)	P	•	•	•	P

• – Included P – Available within a package 0 – Optional ⁽¹⁾Quadra-Trac I is not appropriate for conditions or situations where low range is required, such as severe off-road driving conditions. ⁽²⁾Not compatible with all garage door openers. See your retailer for details. ⁽³⁾Always use seat belts. Children 12 and under should always be in a back seat correctly using an infant or child restraint system, or the seat belt properly positioned, dependent on the child's age and weight. ⁽⁴⁾Intended to provide assistance to the driver. Always exercise appropriate care while reversing. ⁽⁵⁾Must use Bluetooth[™] compatible mobile phone. ⁽⁶⁾Navigation system operates only in certain metropolitan areas. See your retailer for details.

	LAREDO		LIMITED	OVERLAND	SRT8
	E	X	H	P	L
INTERIOR (continued)					
Seats – Heated front (included in SRT Group I)	P	•	•	•	P
– Front continuously variable manual lumbar seat adjustment	•	•	•	•	•
– Eight-way power driver's, manual front passenger seat adjustment	•				
– Eight-way power driver's, four-way power front passenger seat adjustment		•			•
– Eight-way power driver's with memory, four-way power front passenger seat adjustment (included in SRT Group I)			•	•	P
SRT Group I – Includes heated front seats, infrared dual zone climate control, Jeep [®] Memory System, ParkSense [™] Rear Park Assist System, power adjustable pedals, rain-sensitive wiper system, remote starter, SmartBeam headlamp system and UConnect [™] Hands-Free Communication (must have power sunroof)					0
Sunroof – Power with express open/close and comfort-stop features	P	0	•	•	0
SAFETY & SECURITY					
Air Bags⁽³⁾ – Advanced multistage driver and front passenger	•	•	•	•	•
– Advanced side-curtain provide additional protection to front and rear outboard occupants in the event of a collision	•	•	•	•	•
ParkSense^{™(4)} – Rear Park Assist System with shut-off switch (included in SRT Group I)		0	0	•	P
ParkView^{™(4)} – Rear Back-Up Camera (requires navigation system)	P	P	P	P	P
Tire Pressure Monitoring Display System – Features tire valve stem mounted sensors that monitor and display (in EVIC) individual tire pressures for all four rotating tires and warns if pressure is too low or too high			•	•	•
Tire Pressure Monitoring Warning System – Features tire valve stem mounted sensors that monitor pressure and display a warning in the instrument cluster if pressure is too low or too high	•	•			
Vehicle Security System – Monitors doors, flipper glass and liftgate		•	•	•	•
SOUND SYSTEM/ENTERTAINMENT					
Entertainment/Communication – UConnect voice-activated hands-free communication ⁽⁵⁾ (included in SRT Group I)		0	0	0	P
– SIRIUS [™] satellite radio (late availability)		0	0	0	
– Rear DVD Video Entertainment System [™] with DVD player in centre floor console, remote control, two wireless headphone sets, and Rear Seat Video [™] screen in overhead console		0	0	0	0
Navigation/ParkView Group – Includes AM/FM navigation radio with six-disc CD changer, ParkView rear park assist camera and ParkSense rear park assist system		0	0	0	0
Radios – AM/FM stereo radio with CD player, interface for portable audio devices	•	•			
– AM/FM/RDS stereo radio with six-disc CD/MP3 player and clock	P	0	•	•	•
– Full screen GPS/DVD-based navigation system ⁽⁶⁾ with AM/FM/RDS stereo radio, six-disc CD/MP3 player and clock		P	P	P	P
Speakers – Six-speaker system	•				
– Boston Acoustics [®] Premium Sound System with six Boston Acoustics speakers and 276-watt digital amplifier		•	•	•	•



The Authentic Difference: a Jeep® Brand original, by design. Start with something as individual as a Jeep 4x4. Then add Authentic Jeep Accessories by Mopar®, designed and engineered to meet the strict standards expected from the official parts accessories division of DaimlerChrysler Motors Company LLC. That's the Authentic Difference — a difference you can't find anywhere else in the aftermarket. From the boldly rugged styling of Moulded Running Boards to the unending enjoyment of a Navigation Radio, Mopar Accessories are designed by a DaimlerChrysler Engineering Team to offer your Grand Cherokee premium protection, convenience, style or entertainment. With Authentic Jeep Accessories by Mopar, the possibilities are boundless.

GOOD LOOKS CAN TAKE YOU FAR. With the Appearance Package, you'll have the rugged good looks to keep you looking good far off the beaten path.

[A] Chrome Air Deflector | Put the bold good looks right up front with a Chrome Air Deflector, designed to help deflect gravel, dirt and bugs up and away from your windshield.

Chrome Grille | Display your good looks right up front. Premium Grille will not adversely affect engine airflow or impede the opening and closing of the hood. Also available in Brushed Aluminum.

[B] Moulded Running Boards | For a step up in stylish convenience, our Moulded Running Boards are constructed of heavy-gauge steel for safe and easy entry and exit, and feature a Black moulded-grain plastic outer cover for the finishing touch.

[C] Door Sill Guards | Start your day on a bright note while protecting your vehicle's interior sills from scratches. Front Guards prominently feature the Grand Cherokee name.





PREMIUM ELECTRONICS: TURN ON, TUNE IN AND HEAD OUT.

[A] Navus™ Dash Mounted Navigation System | Add advanced and affordable GPS technology to your vehicle. Features include touch screen controls, complete map and points of interest data, turn-by-turn direction prompts, trip information, voice instructions, automatic re-routing and much more.

[B] Navigation Radio (REC) | Sophistication made simple. This combination DVD navigation/stereo system provides you with turn-by-turn directions. Highlights include voice instruction, automatic re-route calculation, full map displays, extensive points of interest listings and much more.

[C] DVD Rear Seat Video™ | No lines and no waiting with this integrated, single-disc CD/DVD featuring a 7-inch (or optional 10-inch) wide screen, wireless headphones and remote.

[D] Remote Start | Hit the ground running with the ability to start your vehicle from up to 244 metres (800 feet) away. The system is designed to operate seamlessly with your vehicle's electronic system. A two-way remote start system is also available.

[E] Premium Radios | Our premium radios feature 66 watts of power and generous AM/FM presets. Selections include:

- AM/FM stereo with six-disc CD player, MP3 and hands-free compatibility.^[1] (RAQ)
- AM/FM stereo with six-disc CD player, MP3 and WMA compatibility. (RAK)

[F] ParkSense™ Rear Park Assist System^[2] | Advanced system uses sound waves and audio-visual indicators to manoeuvre in tight spaces at parking speeds.

[G] Rear-view Camera^[2] | Get an extra set of eyes in the back of your head. The camera's 3½-inch diagonal screen shows a view of what's behind you and includes on-screen markers to help you determine an object's distance from your vehicle.

[H] UConnect™ Hands-Free Communication^[3] | This voice-activated communication system allows you to dial your wireless phone through simple voice commands utilizing a Bluetooth™ Hands-Free Profile wireless phone.

[I] iPod® Interface Module | The FM-bounded system allows you to maintain your music selection through your iPod control buttons.

EVSM I (Electronic Vehicle Security) | Get a lock on security. EVS I is designed to work with your factory-provided keyless entry and provides perimeter and interior protection with horn-honk alarm, starter interrupt and dash-mounted LED (not shown).

^[1]Requires factory-installed UConnect system.

^[2]Intended to provide assistance to the driver.

Always exercise appropriate care while reversing.^[3]Must use Bluetooth™ compatible mobile phone.



COMPASS

PATRIOT

(Coming Spring 2007)

LIBERTY

GRAND CHEROKEE

COMMANDER

WRANGLER

WRANGLER UNLIMITED

Jeep[®]

Learn more @ jeep.ca or call 1-800-361-3700



PRINTED ON PAPER WHICH CONTAINS A MINIMUM OF 10% POST-CONSUMER RECYCLED FIBRE.

PRINTED IN CANADA 5207-C-574E